



The **3S** approach ...
model-based engineering

- 
- 2021** Wolfgang Micus is the only Managing Director
- 2020** More than 300 projects per year for the first time
- 2019** New major versions of SIR 3S, KANEW 3S and HYDKA 3S
- 2016** **30 Years 3S**
- 2013** Wolfgang Micus is appointed as Managing Director,
Company founder Dr.-Ing. Schaper retires from the management board
- 2011** KANEW 3S – Software for analysis and
simulation of Asset-Strategies
- Establishment of office location Dresden,
Ingo Kropp receives procuration
- 2009** Establishment of office location Karlsruhe,
Dr.-Ing. Jochen Deuerlein receives procuration
- 2007** Release of SIR 3S version 8,
Introduction of database model management
- 2005** Establishment of office location Munich
Dr.-Ing. Andreas Wolters is appointed as Managing Director
- 2004** Wolfgang Micus receives procuration,
Prof. Dr.-Ing. Bernd Uwe Rogalla leaves the management board
- 1995** HYDKA 3S is published as Windows-Version
- 1994** SIR 3S is published as Windows-Version
- 1992** Dr.-Ing. Bernd Uwe Rogalla is appointed as Managing Director
- 1991** First versions of the company's software products SIR 3S
(Flow processes in pipeline systems) and HYDKA 3S
(Hydraulic calculations of wastewater treatment plants
and open channel systems) are available
- Relocation of the headquarters of 3S Consult GmbH
from Hanover to Garbsen
- 1986** **15.05.1986** - Foundation of 3S Consult GmbH as a spin-off of
the Institute of Fluid Mechanics at the Leibniz University Hanover
by Dr.-Ing. Hartwig Schaper, Prof. Dr.-Ing. Werner Zielke
- Dr.-Ing. Hartwig Schaper is appointed as Managing Director



Where does 3S work?

For more than **35** years **3S** has been successfully working in the field of Hydraulic Engineering and Asset Engineering applying its own software products.

For distribution networks for gas/water/heat/cooling/electricity, sewer systems, pipelines, caverns and plants.

We combine your knowledge with our **experience**.



*The management board of 3S (from left to right)
Dr.-Ing. Jochen Deuerlein, Dipl.-Ing. Wolfgang Micus
and Dipl.-Ing. Ingo Kropp*



Flows of liquids and gases occur in various types in our nature and in technical systems

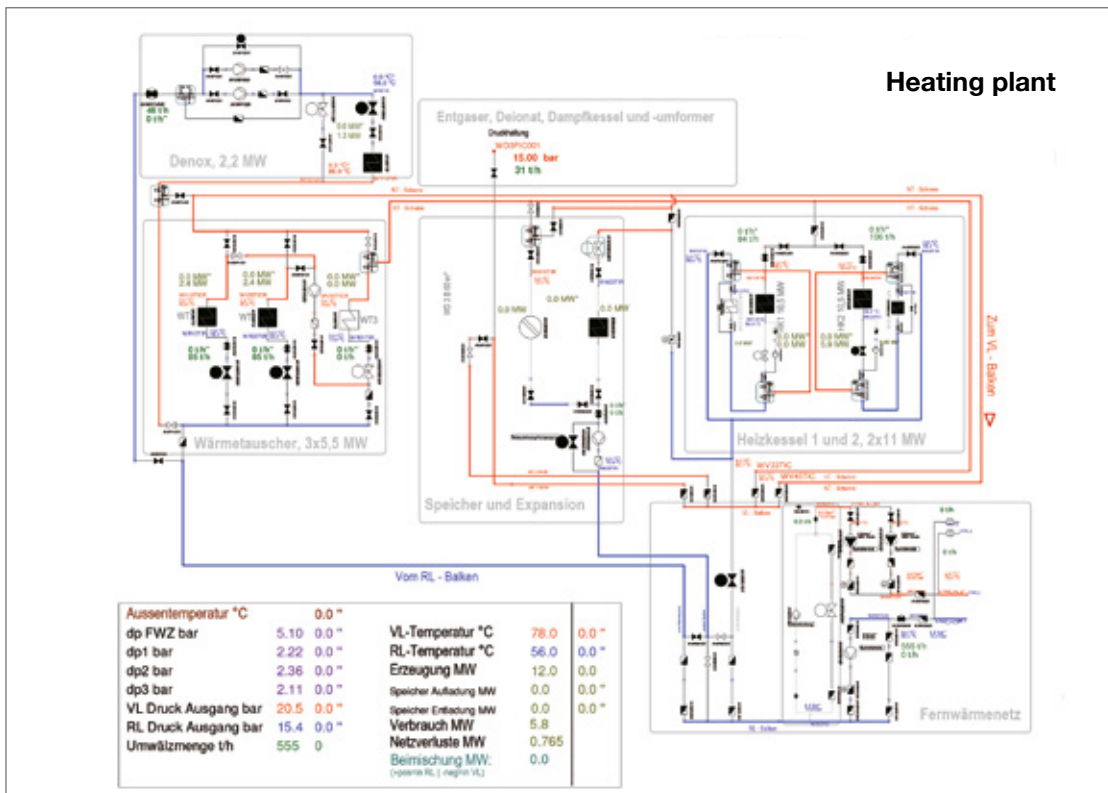

For the description and analysis of dynamic flow processes in complex pipeline systems, adequate models are required

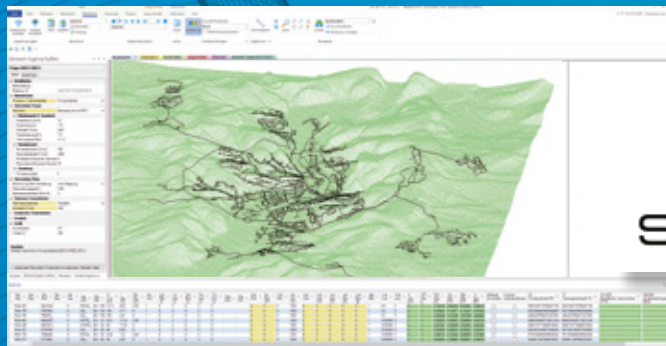

With our software products SIR 3S, KANEW 3S and HYDKA 3S you can answer all questions in hydraulic analysis and asset management for pipeline systems.

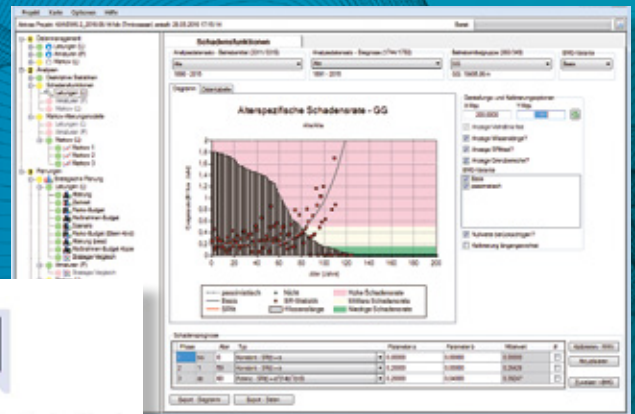
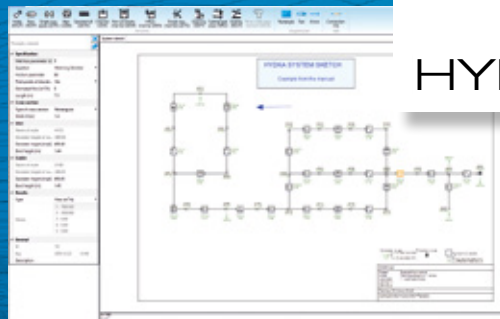

What does **3S** stand for?

Strömung (Fluid Flow), Struktur (Structure), Software

The first S of **3S** stands for fluid mechanics. Since the main task of a pipeline system is the fluid mechanical transport of liquids or gases.

Geographic and operational information systems (GIS, AIS), ERP, SCADA control system – the planning and proper management of pipe networks requires various software and a number of people.

The second S of **3S** stands for structure. Complexity can't be properly analyzed without high quality and realistic models.

Due to aging of the technical infrastructure and rehabilitation backlogs, economic approaches are getting more and more important beside the hydraulic analysis. They are aggregated in the field of analytical Asset Management.

Analytical engineering is based on software. The **3S** approach needs **3S** software. The third S of **3S** stands for Hydraulic - and Asset-Engineering-Software: SIR **3S**, KANEW **3S** and HYDKA **3S**.

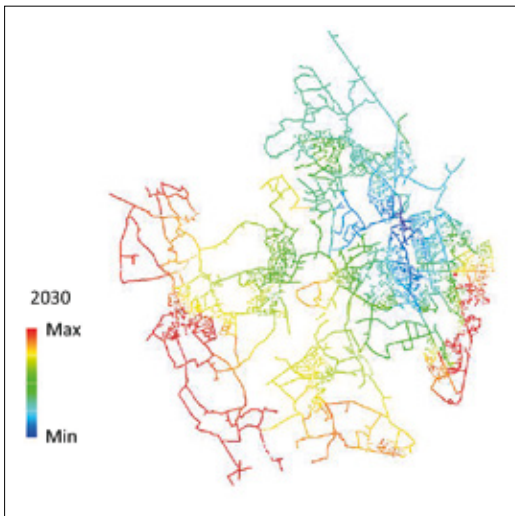

Analysis of the existing state and measurements as a basis for model calibration are mandatory for realistic, reliable and model-based optimization and expansion planning for plants and networks.

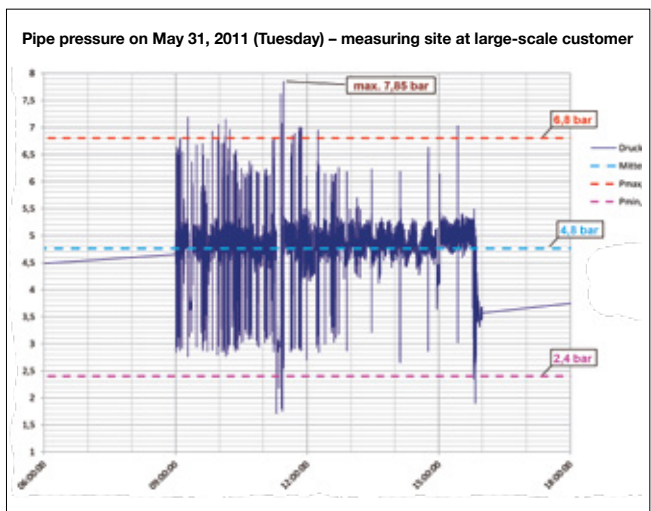

Municipal supply networks are modeled in detail – including house connections and meters





How does **3S** work?

We call it the **3S** approach – the model-based consulting (engineering).

With our own software SIR **3S**, KANEW **3S** and HYDKA **3S** we support you in solving any operational problem and in optimizing your systems performance.

Our goal is to establish a fruitful collaboration with you and the stakeholders from different departments: strategy, planning, operations and maintenance.

As a result of our more than 30 years of experience in various systems we have the ability to quickly understand the system operations of your facility as well as to go into the required level of detail.

We map your real system to an appropriate realistic mathematical-physical model. After successful calibration, the model can be used for different tasks such as optimization, validation or numerical proof of plant safety.

The existing model can also be used for rehabilitation planning.

The combination of our wide experience with sophisticated mathematical methods greatly supports also the successful planning of new systems (“green field”- projects).

For this purpose, we consider interdisciplinary aspects which are an important part of our consulting activity.

More than two hundred successfully performed projects every year bear witness to the full satisfaction of our clients.

We aim at establishing a long-term relationship with our clients by providing advice and assistance through completion of a particular job and beyond. We consider ourselves lucky for having been able to assist many of our clients for decades as competent consultants with the **3S** approach.



Software

- Simulation of fluid flows in pipe networks
- Various tools for the analysis of large and complex pipe networks and plants

Consulting Services

- Calculation of pressure surges
- Hydraulic analysis
- Green field planning
- Asset Management
- Optimization

Your Benefits

- Creation of models and engineering services from one source
- Individual customization of software
- Integration within operative core systems
- Accurate and realistic models
- Hands-on training with your own simulation
- Help desk



Our employees assist you with the set-up of your model, providing solutions for specific problems and the implementation of individual software solutions. Furthermore, the helpdesk supports you in the daily usage of our software.



Is 3S a normal engineering company?

Yes. If you need specific hydraulic or asset simulations (e.g. hydraulic network calculations, calculation of pressure surges (water hammer) or rehabilitation planning) – just ask **3S**.

If you need a series of calculations for network planning, capability analysis, estimation of reliability and resilience, risk analysis, asset strategy or optimization – just ask **3S**.

And no. If you are looking for an engineering company which can also sell and lease the corresponding software – at the beginning or in the course of our cooperation – just ask **3S**.

If you are looking for a software company that can enable you to work like an engineering consultant with its own software products – just ask **3S**.

If you are looking for a service provider who can switch quickly between engineer, consultant and software helpdesk – just ask **3S**.

Real plant

Mathematical-physical model, simulation results

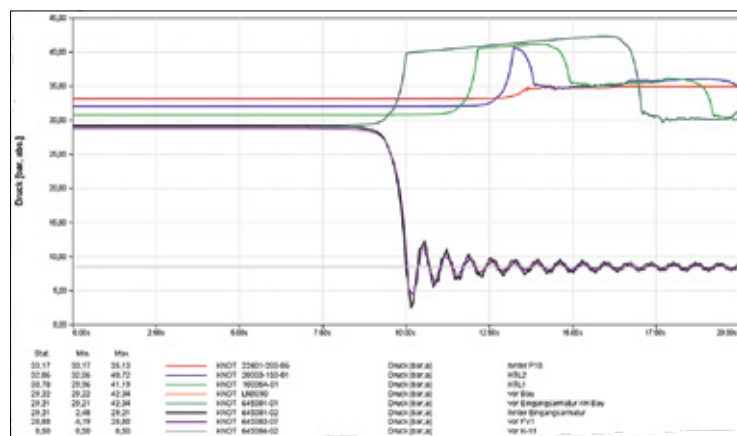
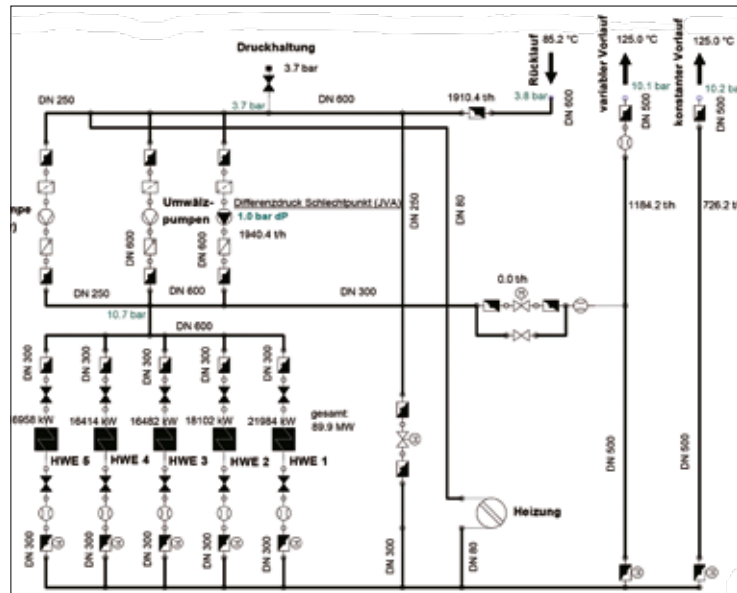
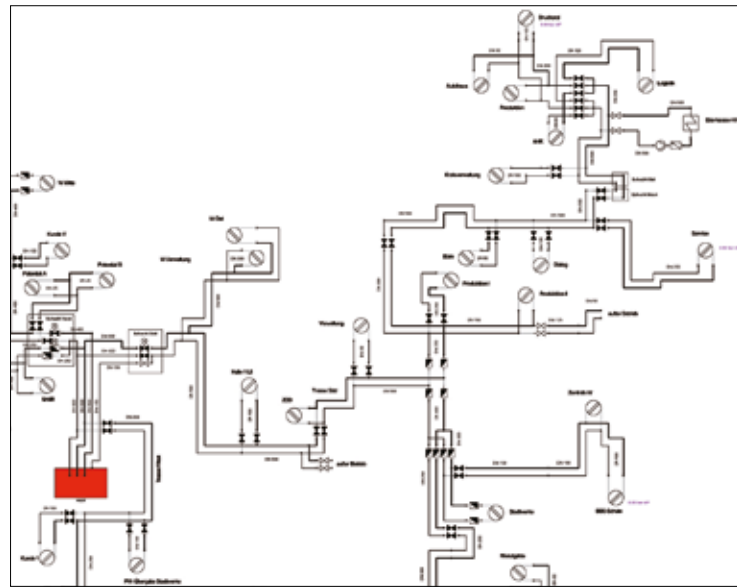

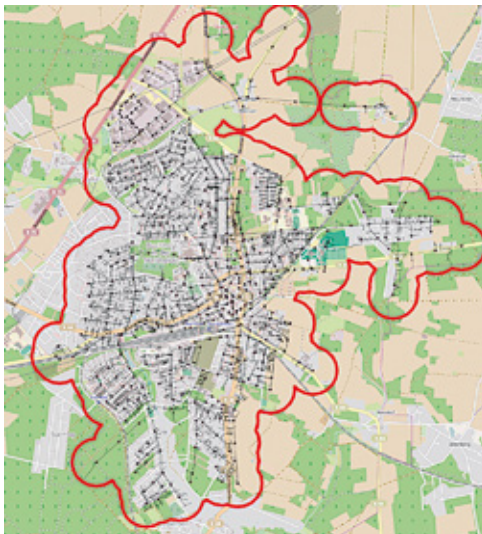

Network model, background map and capacity of fire hydrants



Which systems are handled by 3S?

- ▶ Supply pipe networks gas/water/heat/cooling/electricity
- ▶ Pressurized sewer systems
- ▶ Transport pipelines, caverns and plants

The capabilities and the modular design of our three software products SIR **3S**, KANEW **3S** and HYDKA **3S** permit to work on numerical models for plants with only few meters of extension and complex process characteristics as well as very large and meshed supply networks or long-distance pipeline systems.

The fluids are described by their thermo-physical characteristics. In combination with the model components like pipes, channels, pumps, turbines, fittings, valves (for controlling or throttling, aeration or air relief), tanks, boiler, basin, ventilation, etc. they provide the basis for simple or complex steady-state calculations or extended period and slow transient simulations on a daily or annual basis. High frequency computations of fast transients with time steps of a few milliseconds are also possible. Physical characteristics (friction, inertia, compressibility) can play a significant role in the solution process, but also thermo-hydraulic effects, the water age or the mixing of fluid parameters.

The data from the information systems of our clients that are fundamental for the creation of hydraulic simulation models can also be used for developing asset management models for rehabilitation and investment planning which are based on condition assessment and aging models. In this view, hydraulic and reliability aspects can also be taken into account.

Beside the close contact to our clients our strengths include the proper processing and presentation of results. A comprehensive documentation completes all business activities of **3S**.

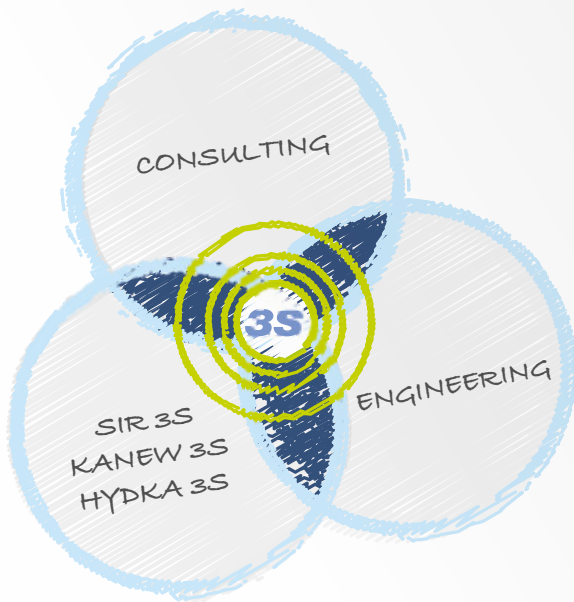

+ Experience
 + Close contact with clients
 + SIR 3S, KANEW 3S
 and HYDKA 3S
 = Optimal Solution!



How we can assist you...

Fields of work

► In general:

- Infrastructure, energy, industry, supply and disposal systems, ... wherever pipes play an important role

► In detail:

- Supply networks (water, heat, cooling, gas, steam) including plants and other facilities (waterworks, heat/cooling generation systems, facilities for pressure increase or pressure reduction, energy recovery via turbines, heat storage plants)
- Regional water transportation systems
- Waste water (pipeline systems, channel systems and basins)
- Pipelines (gas, oil, products, brine)
- Refineries and chemical plants
- Caverns (gas, oil)
- Irrigation and drainage systems (e.g in open pit mines)
- Wells, pumped storage hydropower plants
- Cooling water circuits
- Refueling systems
- Pipe systems in buildings
- Power grids (Asset-Analysis)

Range of services – Hydraulics

- ▶ Design, implementation and evaluation of measurement campaigns with own equipment and employees (operational and pressure surge measurements)
- ▶ Steady-state calculations and slow transient simulations
 - Analysis and improvement of the existing state of the system
 - Calculations for design/planning
 - Calculations of capacity (for instance firefighting capabilities)
 - Transport, reaction and mixing of fluid quality parameters
 - Flow times („Water age“)
 - Influence areas and source tracking
 - Calculation of characteristic curves
 - Diameter optimization, optimization of network topology
 - Creation and optimization of flushing programs
 - Green field planning
- ▶ Water hammer (fast transient) simulation
 - Pressure surges and resulting forces (Flow loads)
 - Proof and design of surge control measures and concepts
- ▶ Operation, control
 - Design, analysis and optimization of operational modes and control strategies
 - Determination of characteristic curves, selection of fittings, pumps, control devices
 - Optimal location for measurements (for pressure, quality, flow) in the network (optimal allocation of sensors)
 - Feasibility studies, e.g. integration of decentral heat production plant into existing networks
 - Development of operating manuals and specifications

Range of services – Hydraulics und Asset Management

- ▶ Condition assessment and risk assessment
- ▶ Service life analysis
- ▶ Determination of rehabilitation needs
- ▶ Simulation of short-, medium- and long-term asset scenarios and maintenance strategies following ISO 55000:
What If, service level, CAPEX/OPEX optimization, risk management, sector coordination
- ▶ Rehabilitation work planning
- ▶ Reliability calculations
- ▶ Green field and brown field planning combined with maintenance planning

Range of services – Hydraulics, GIS and SCADA

- ▶ GIS-integrated calculations of the network
- ▶ Built-in simulations in control systems (SCADA):
Leak detection, online near real-time simulation, reconstruction, what If, look ahead, reference
- ▶ Training simulators
- ▶ Analysis and improvement of control system user interfaces



Contact

Dresden

Ingo Kropp



Schillerplatz 2
D 01309 Dresden
Tel. +49-351-48245-31
Fax +49-351-48245-50

Garbsen

Wolfgang Micus



Osteriede 8-10
D 30827 Garbsen
Tel. +49-5131-4980-0
Fax +49-5131-4980-15

Karlsruhe

Jochen Deuerlein



Albtalstraße 13
D 76137 Karlsruhe
Tel. +49-721-33503-360
Fax +49-721-33503-130

Munich

Andreas Wolters



Am Harras 10
D 81373 München
Tel. +49-89-5404146-50
Fax +49-89-5404146-97

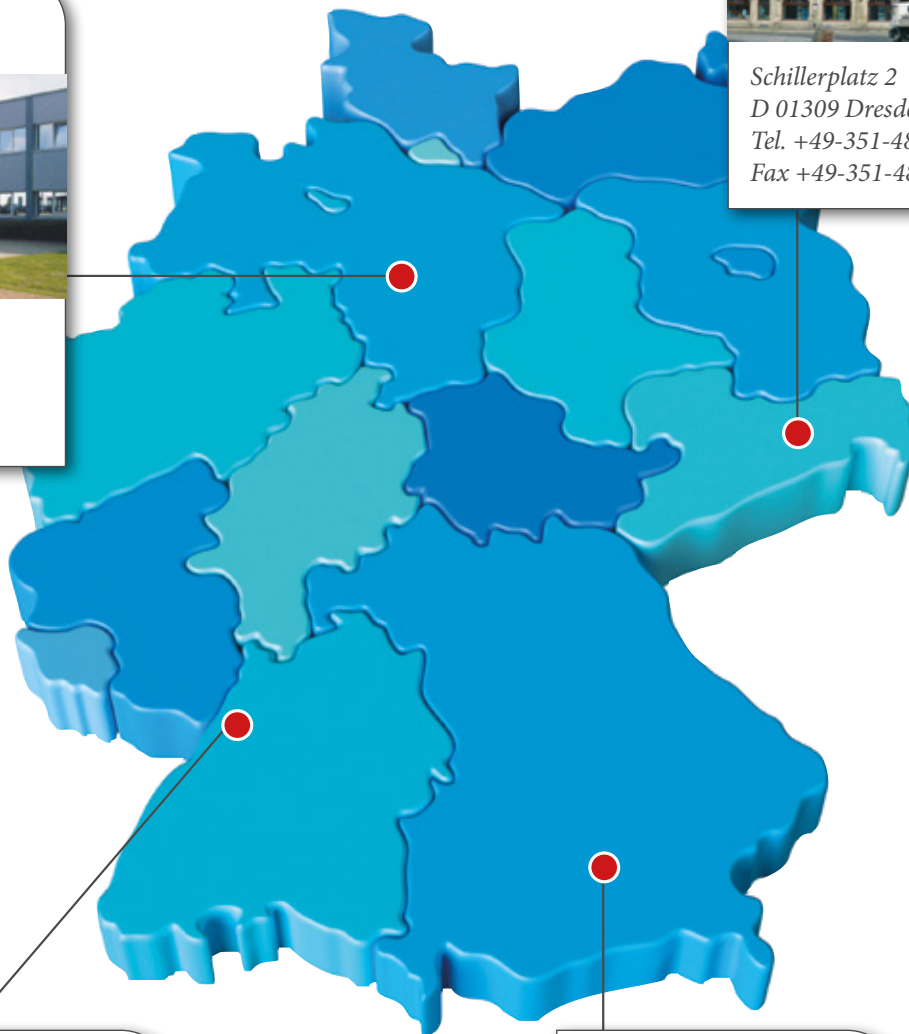

Legal information

Publisher

3S Consult GmbH • Osteriede 8-10 • D 30827 Garbsen
Tel.: +49-5131-4980-0 • E-Mail: info@3sconsult.de
Managing Director: Wolfgang Micus

Registered office: Garbsen
Trade register HRB 110404 – Local court Hanover, Germany
Sales tax identification number DE 115831439

Design MEODesign

Print diedruckerei

Images Page 1 Fotolia/Wolfi30, (4) Shutterstock;

Page 5 Fotolia/Marco2811;

Page 8 Fotolia/nyul, Fotolia/Marco2811;

Page 12 Fotolia/Irochka; **Page 14** Fotolia/fotomek

Fotograph Salih Usta

The use of the logos on the back of this brochure is done
with kind permission of the respective companies.

We combine your knowledge

ExxonMobil

uni
per

ENNI
Energie & Umwelt Niederrhein

VATTENFALL

SWP

RheinEnergie

TÜVRheinland®
Genau. Richtig.

STADTWERKE
MARBURG

steag

SW/M
Stadtwerke München

STORAG ETZEL
Energy Storage Solutions

H₂O
OSLO

sgsw
St.Galler Stadtwerke

RWE

Lovion

PÖYRY

NWO
Nord-West Oelleitung

LINEG

LOTZ AG
INGENIEURE

NWKG

KSB

HYDRO:ingenieure
Energy & Wasser GmbH

GELSENWASSER
EAL STROM NUTZGAS WASSER

GIFTGE
CONSULT

thuga

pecher

stadtwerke
flensburg

UNIVERSITÄT
DUISBURG
ESSEN

K+S

Fraunhofer
IOSB

FICHTNER
WATER & TRANSPORTATION

xylem
Let's Solve Water

EVS

BORN | ERMEL | Ingenieure

wintershall

enercity
positive energie

eins
energie in sachsen

Bodensee-
Wasserversorgung

PORTA
INGENIEURE PLANER GEOMETER

BASF
We create chemistry

ACTEMIUM

aqua consult
Ingenieur GmbH

with our experience.

3S Consult